

WINCO INC[®]

A Division of **DTE** Dyna Technology Inc

INSTALLATION INSTRUCTIONS FOR 2-WIRE AUTO START CONTROL CONVERSION

The following instructions are provided to convert the ULPSS15B4W/E from a special 4-wire start system to a standard 2-wire Auto Start System.

Items required:

WINCO Conversion Kit # 16448-005 Auto Start (for ULPSS15B2W/E)
T25 Torx Screwdriver
7/16" End Wrench or Socket & Driver

PROCEDURE

1. Move the left hand toggle switch "A" to the "STOP" position.
2. Remove the battery negative (-) cable if the battery is installed.
3. Unplug the wiring harness "D".
4. Remove the two bolts "B" and remove the circuit breaker cover panel "E".
5. Remove the 4 torx screws "G" from the tower assembly.
6. Remove the 4-wire controller "C" by pulling it forward.
7. Install 2-wire controller "F" by pushing the controller back into position.
8. Re-install the 4 torx screws "G".
9. Re-connect the wiring harness "D".

REMOVE REAR DOOR FOR ACCESS
TO THE CONTROLLER TOWER

REAR VIEW

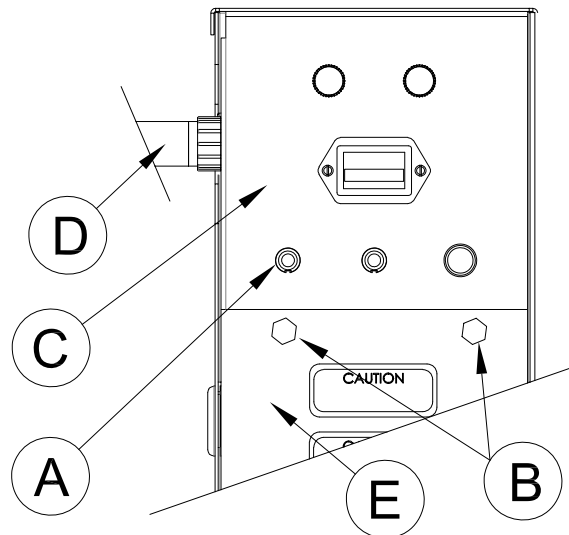
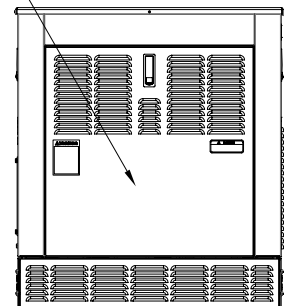

10. Locate the 2-wire white connector, hanging loose on the right hand side of the control tower. Attach it to the matching connector "H" on the bottom of the new controller "F".

11. Replace the circuit breaker cover panel "E" and re-install the 2 bolts "B".

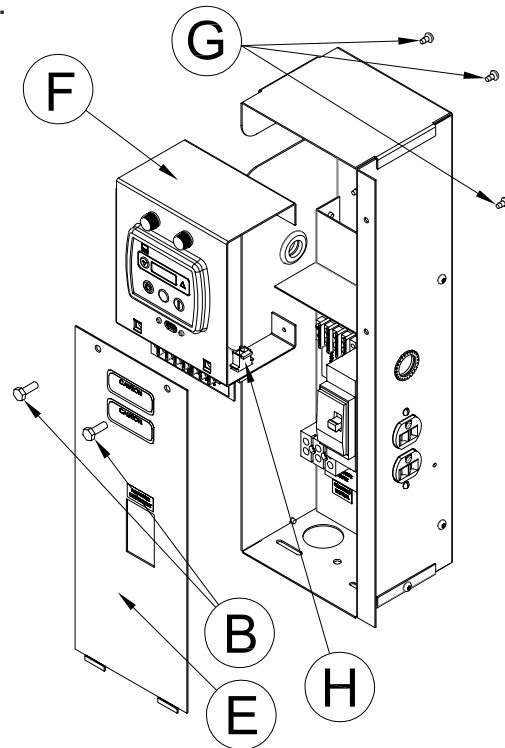

12. Remove the right side door.

13. Locate the 2-wire white connector on the right side of the engine. Unplug the white connector and tie back if necessary. See picture below.

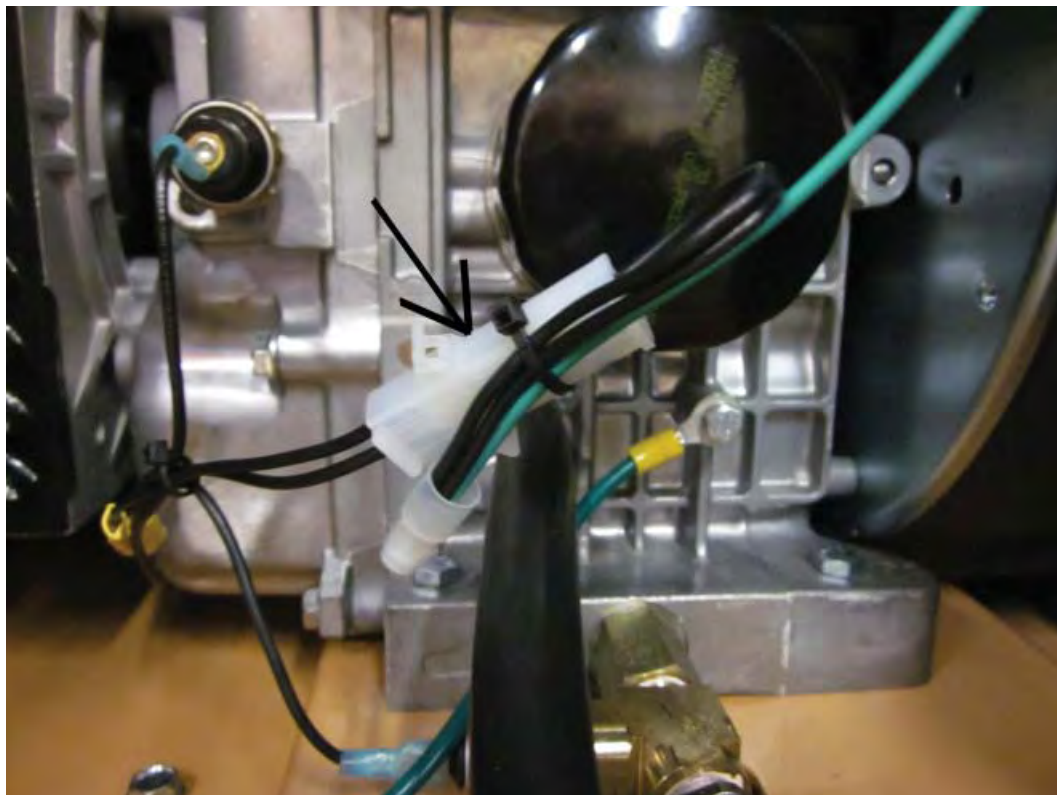

14. Replace the right side door.

15. Re-attach the battery cable if done so earlier.

16. Remove the the operators manual part # 60706-206 for model ULPSS15B4W/E from the literature package and replace it with operators maual part # 60706-207 for model ULPSS15B2W/E. This replacement manual contains the proper information for installation and operation of a 2-wire auto start system. The customer must have this manual in order to start and operate the unit after the installation of the new engine control.

17. Replace the rear door.

18. Using the new operators manual, this unit is now ready to be installed as a standard 2-wire start system. This generator set will now work with any transfer switch that provides a 'dry' relay closure for a start/run signal.

If you have any problems or need assistance,
feel free to contact the WINCO Service
Department at 507-357-6831.

WINCO INC[®]
*A Division of **DTI** Dyna Technology Inc*

**225 S. CORDOVA AVE.
LECENTER, MN 56057
507-357-6821
SERVICE DEPT.
507-357-6831**

60710-127-11350-00