

WINCO INC[®]

A Division of **DTE** Dyna Technology Inc

INSTALLATION INSTRUCTIONS FOR 2-WIRE AUTO START CONTROL CONVERSION

The following instructions are provided to convert the ULPSS8B4W/E from a special 4-wire start system to a standard 2-wire Auto Start System.

Items required:

WINCO Conversion Kit # 16448-007 Auto Start
T25 Torx Screwdriver
7/16" End Wrench or Socket & Driver
Wire Side-Cutter
Wire Crimper

PROCEDURE

1. Remove right side panel, rear door, left side door and roof.

REMOVE THE SMALL RIGHT SIDE PANEL, REAR DOOR, LEFT SIDE DOOR AND ROOF FOR EASY ACCESS.

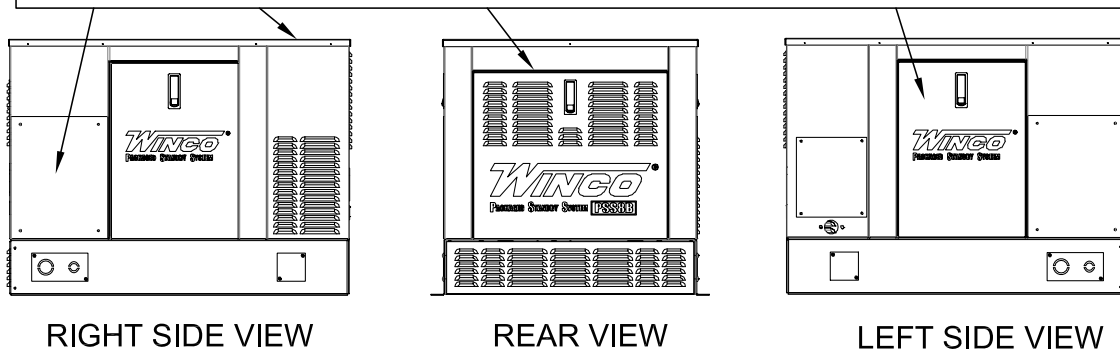

2. Move the left hand toggle switch "A" to the "STOP" position.
3. Locate the two wires connected to the left side of the engine. Remove the wires from the bolt by taking the nut off. Cut the terminal connector off each wire. Crimp a wire cap to each wire individually. Replace the nut. See picture on page 2..

REMOVE THESE
TWO WIRES
FROM THE
BOLT, CUT
AND CAP THE
WIRES
INDIVIDUALLY.
REPLACE THE NUT.

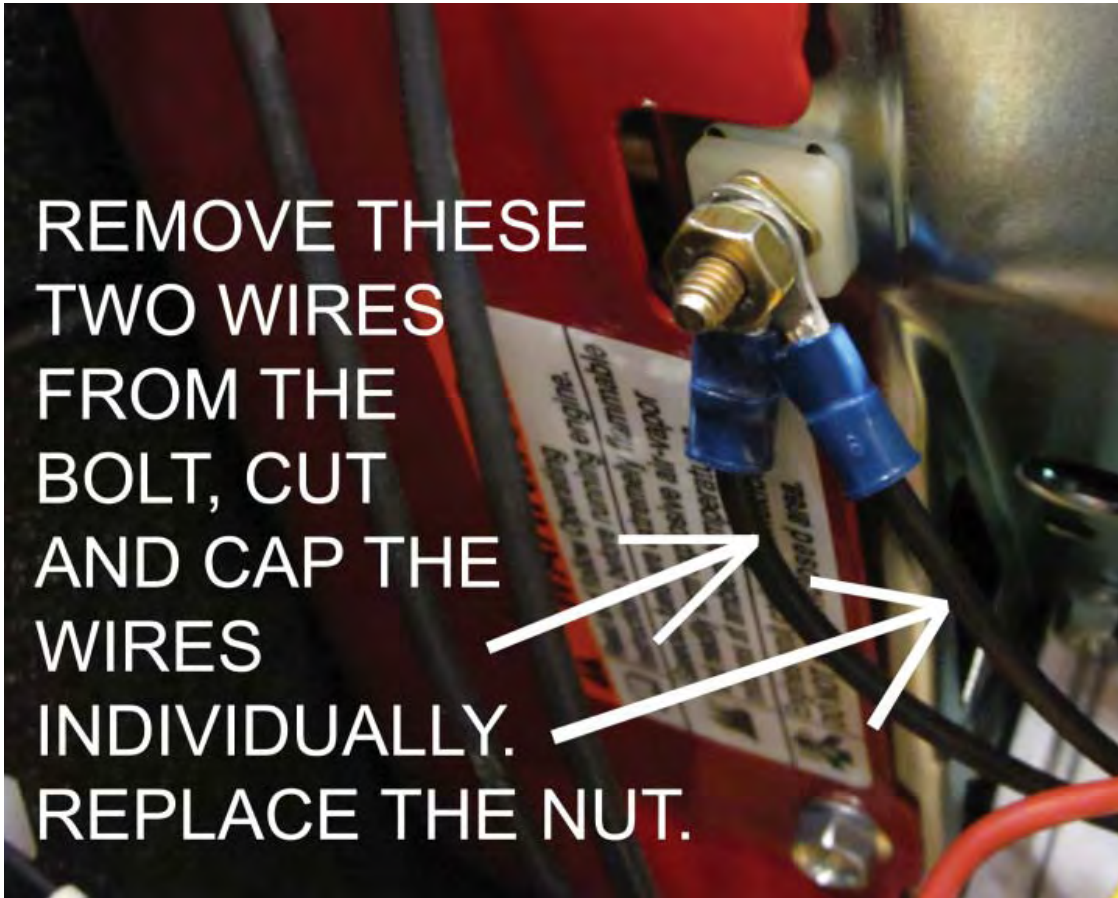

4. Remove the battery negative (-) cable if the battery is installed.

5. Unplug the wiring harness "D".

6. Remove the two bolts "B" and remove the circuit breaker cover panel.

7. Remove the 6 torx screws "G" from the tower assembly.

8. Push the plastic grommet "H" into the box to ease in pulling the wiring harness through the hole.

9. Remove the 4-wire controller by pulling it forward while guiding the wiring harness through the hole "H".

10. Remove the plastic grommet and put it aside to re-install later.

11. Install 2-wire controller "F" by guiding

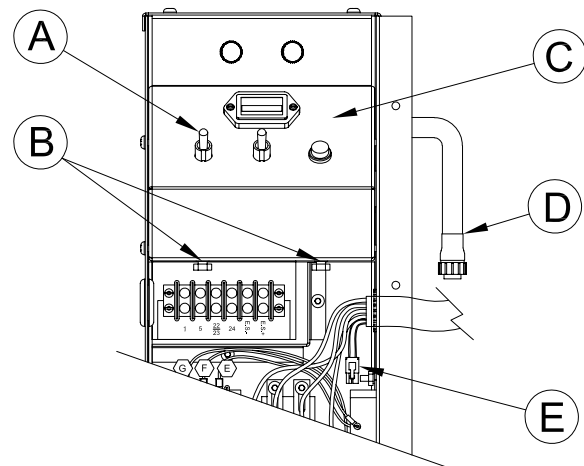

the wiring harness through the hold and pushing the controller back into position.

12. Re-install the 6 torx screws "G".

13. Re-install the plastic grommet "H".

14. Re-connect the wiring harness "D".

15. Connect 2-wire white connector "E" to the matching connector "I" on the bottom of the new controller.

16. Replace the circuit breaker cover panel and re-install the 2 bolts "B".

17. Remove left side door.

18. Replace left side door.

19. Re-attach the battery cable if done so earlier.

20. Replace the right side access panel and roof.

21. Remove the operators manual part # 60706-210 for model ULPSS8B4W/E from the literature package and replace it with operators manual part # 60706-211 for model ULPSS8B2W/E. This replacement manual contains the proper information for installation and operation of a 2-wire auto start system. The customer must have this manual in order to start and operate the unit after the installation of the new engine control.

22. Replace the rear door.

23. Using the new operators manual, 60706-211, this unit is now ready to be installed as a standard 2-wire start system. This generator set will now work with any transfer switch that provides a 'dry' relay closure for a start/run signal.

If you have any problems or need assistance, feel free to contact the WINCO Service Department at 507-357-6831.

