

# User's Guide

The ASCO Catalog 5350 ATS Remote Annunciator provides remote visual status reporting and push-button testing of up to eight ASCO automatic transfer switches.

This User's Guide provides operation information after the ATS Remote Annunciator has been installed and configured. It also includes basic troubleshooting.

Refer to **Installation Manual 381333-315** for mounting, wiring, and configuration.

## ATS Remote Annunciator Catalog 5350

TABLE OF CONTENTS		page
Operation	.	2-3
Control key switch	.	2
Lamp test button	.	2
Alarm silence button	.	2
Transfer test	.	2
Flashing light	.	3
Reset button	.	3
Troubleshooting	.	4

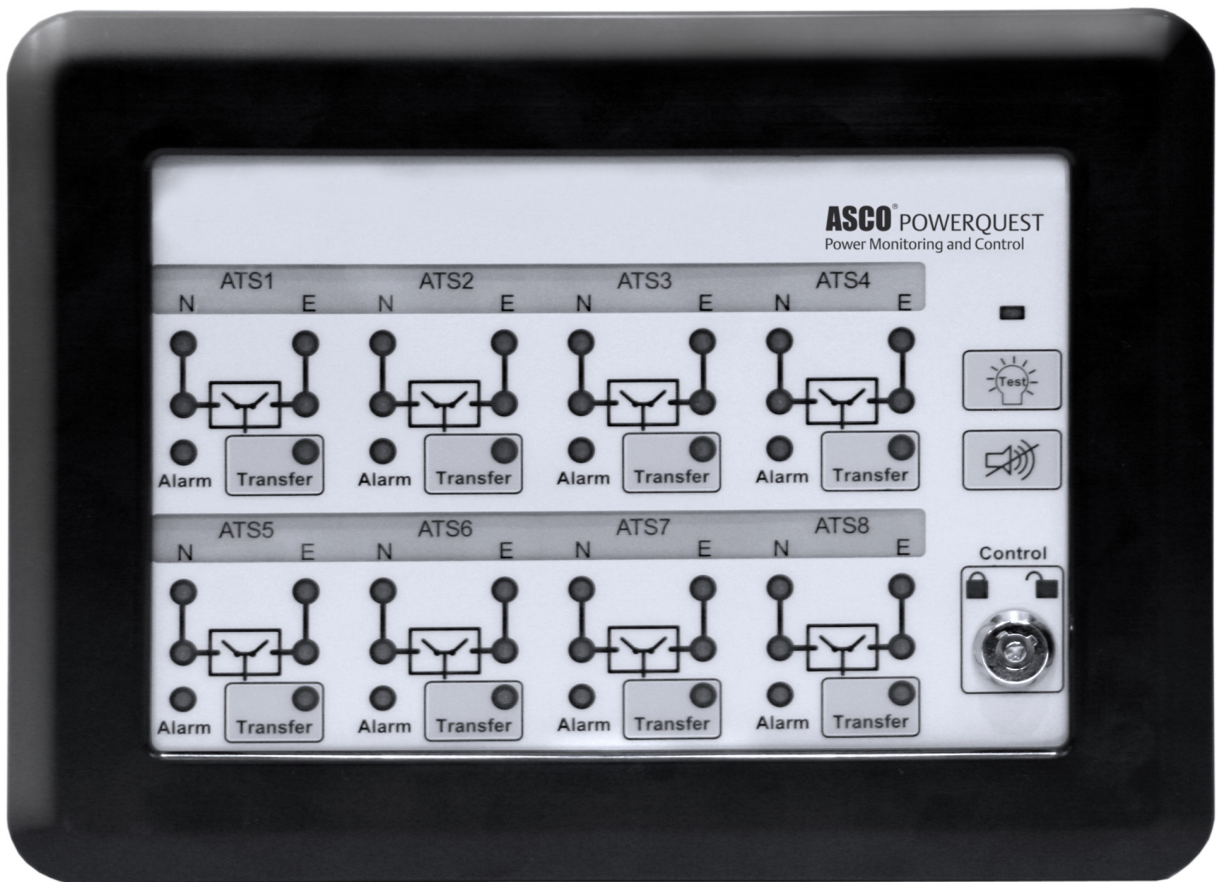

**381333-314 A**

# Operation

The ASCO 5350 ATS Remote Annunciator communicates with ASCO automatic transfer switches (ATSs) to report their status. The ATS Annunciator polls each ATS and obtains its status. Lights indicate which ATSs are connected to the normal source or emergency source. Source acceptability status for each ATS is also shown. In addition, the ATS Remote Annunciator can send commands to individual ATSs to control their operation.

A control key switch prevents unauthorized operation. Transfer test buttons (one for each ATS) simulate a normal source outage and transfer the individual loads to the emergency source, if acceptable. The same buttons are used to retransfer the load back to the normal source. When the buttons are held, any active time delay is cancelled. Lights in the buttons indicate which ATS is in the test mode and if a time delay is active.

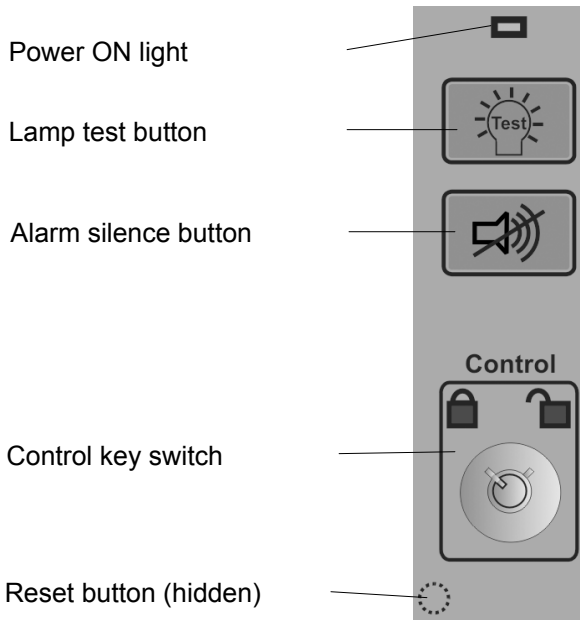

Figure 1: Control buttons

## 1 Control key switch



The **Control** key switch prevents unauthorized operation of the ATS Remote Annunciator. The key can be removed in either the locked or unlocked positions. In the locked position (left), the buttons do not operate. In the unlocked position (right) all buttons function.

## 2 Lamp test button



Press and release the lamp **Test** button to briefly turn on all lights; they will go off after a few seconds. This operation verifies that all the lights work on the ATS Annunciator.

## 3 Alarm silence button



Press and release the alarm silence button to turn off the audible alarm sound. This action also opens the alarm relay contacts. Do not hold the button. These are the possible alarm conditions:

Alarm Condition	Product
communication error	all
locked out	4000 & 7000
ATS position error	4000 & 7000
failure to synchronize	4000 & 7000
extended parallel	4000 & 7000
controls not in automatic	4000 & 7000
ATS bypass active	7000

### NOTICE

Before using the transfer button, be sure conditions are safe for running the generator and for load transfer.

## 4 Transfer test

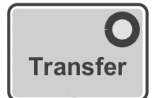

The following operation starts the generator and transfers the load. Be sure that conditions are safe to do this operation.

### 4-1 Load Transfer to Emergency source

To transfer the load from the normal source to the emergency source, follow this procedure:

1. Turn the **Control** key right to the unlocked position.
2. Select ATS that you want to operate (by ATS no. or name).
3. Press and release the **Transfer** button below the selected ATS (do not hold the button).
4. Observe that the **E** light comes on (generator acceptable).
5. Observe that the light in the corner of the button blinks (transfer time delay active, if used).

6. Observe that the ATS connected lights change position (transfer from normal to emergency).
7. To retransfer the load back to Normal go to section 4-2.

Note:

If Feature 2B transfer to emergency time delay is used, the transfer may not occur for up to 61 minutes (depending upon the ATS and the setting in the controller).

To bypass (cancel) this time delay, press the **Transfer** button again and hold it for more than 5 seconds until you hear a beep.

### 4-2 Load Retransfer to Normal source

To retransfer the load from the emergency source back to the normal source, follow this procedure:

1. Turn the **Control** key right to the unlocked position.
2. Select ATS that you want to operate (by ATS no. or name).
3. Press and release the **Transfer** button below the selected ATS (do not hold the button).
4. Observe that the **N** light comes on (utility acceptable).
5. Observe that the light in the corner of the button blinks (retransfer time delay active, if used).
6. Observe that the ATS connected lights change position (transfer from emergency to normal).
7. Turn the **Control** key left to the locked position, then remove it.

Note:

If Feature 3A retransfer to normal time delay is used, the transfer may not occur for up to 61minutes (depending upon the ATS and the setting in the ATS controller).

To bypass (cancel) this time delay, press the **Transfer** button again and hold it for more than 5 seconds.

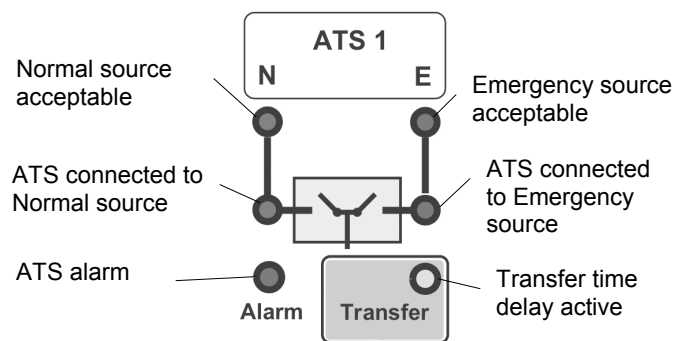

**Figure 2: Status lights and Transfer button**

Note: Alarms can be specific to ATSs or a general communications error or any configured alarm via the Power Manager.

## 5 Flashing light (time delay)

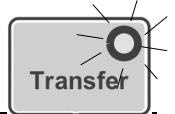

The light in the **Transfer** button flashes when a transfer time delay is active. The faster the blinking, the shorter the delay:

1/10 sec. blink	0 to 5 second transfer delay
1/4 sec. blink	5 to 15 second transfer delay
1/2 sec. blink	15 to 60 second transfer delay
1 sec. blink	over 1 minute transfer delay

## 6 Reset button



A hidden reset button is located just below the **Control** key switch (see Figure 1). The **Control** key switch must be unlocked. The reset button and alarm silence button work together as follows:

### 6-1 Soft reboot reset (keeps user's configurations)

The soft reboot retains the configurations that you have made. To perform a soft reboot, press and hold the hidden reset button and the alarm silence button together for no more than 3 seconds. The configuration parameters remain unchanged.

### 6-2 Hard reboot reset (factory default configuration)

The hard reboot resets all user configuration parameters to factory default settings. The configurations that you have made will be erased. To perform a hard reboot, press and hold the hidden reset button and the alarm silence button together for more than 15 seconds. The default configuration parameters are:

IP Address      169.254.1.200  
 Subnet          255.255.0.0  
 Gateway        0.0.0.0

Other factory default parameters could be checked through Ethernet interface with computer.

# Troubleshooting

Number	Symptom	Probable Cause	Recommended Action
1	Power ON light is off	The DC or AC power source is inadequate or off.	Restore the DC or AC power supply. Check the terminals, fuse, circuit breaker.
2	Lamp test button does not work. Alarm silence does not respond. There is no response on any key.	The <b>Control</b> switch is locked.	Insert <b>Control</b> key and turn it to unlock.
3	The power ON light is blinking.	The unit keeps on resetting due to watchdog-reset possibly due to corruption of software.	Refer to Installation Manual 381333-315. Try to reprogram the unit with the latest software.
			Contact ASCO Services for replacement. 800-800-ASCO or <a href="mailto:customercare@asco.com">customercare@asco.com</a>
4	<b>Transfer</b> button does not work (load transfer does not occur).	Button not held long enough.	Hold the button for at least 5 seconds until you hear a beep..
		ATS Annunciator could have changed to default settings.	Refer to Installation Manual 381333-315. Use the configuration details entered on page 2; reconfigure the ATS Annunciator.
5	Buzzer is beeping continuously.	Communication with the Power Manager may have stopped.	Refer to Installation Manual 381333-315. Check the Ethernet connections: ATS Annunciator to the LAN and Power Manager to the LAN.
6	Communication alarm occurs but all configurations are correct.	Communication protocol may not be the same as that of the Power Manager (if present).	Refer to Installation Manual 381333-315. Verify that the protocol on both devices is the same.
7	A light does not come on when a corresponding button is pressed.	ATS Annunciator is not functioning properly.	Contact ASCO Services for replacement. 800-800-ASCO or <a href="mailto:customercare@asco.com">customercare@asco.com</a>
8	A light does not come on when the lamp test button is pressed.	ATS Annunciator is not functioning properly.	Contact ASCO Services for replacement. 800-800-ASCO or <a href="mailto:customercare@asco.com">customercare@asco.com</a>

