

Booster Pump Installation Instructions

SunPumps SCB Multi-Stage DC Centrifugal Booster Pumps were designed to boost water pressure in a stand-alone pressure system or to deliver water up hill to higher ground. These pumps are very high quality and function very well if the water source is level with or slightly above the centerline of the first pump impeller. These SCB series booster pumps are not self priming and have limited suction lift capabilities such as 3 to 4 feet below the impellers and then only if a dependable foot valve is attached to the end of the suction pipe.

- If attached to a storage tank, install a check valve on the intake line to the pump or next to the discharge/outlet of the pump.
 - If the pump can be installed approximately level with the water source, such as a lake, river, spring box, etc., install a reliable spring loaded foot valve with perforated strainer or screen on the intake line to the pump.
- Inspect the check valve or foot valve to be sure it seats properly and that it is free to open and close freely and with minimal force applied. A leaky foot valve may cause problems in keeping the pump primed. Normally foot valves (and some check valves) are intended to operate in a nearly vertical position.
- Install the first length of intake pipe to the water source and if it is in a "foot valve" application, fill the pipe with clean water. If the water recedes, a leak is indicated. If the leakage is not present, attach a pipe tee on the intake pipe somewhere close to the actual pump intake. This "priming tee" is to allow for the best priming of the pump.
- Prime the pump by pouring clean water into the pipe tee until the water comes out of the discharge pipe. Especially if the pump is used in horizontal position and to be sure the air has been purged from the pump impellers, a short vertical stand-pipe may be temporarily installed in the pipe tee and the discharge outlet. (These may be removed after priming if not required for the normal piping needs). In either case, be sure that all pipe joints in the intake piping and the pipe plug in the priming tee do not leak - use thread sealant. Air leaks in the intake line will cause priming problems. **(CAUTION: Never start the pump dry, it must be filled with water first.)**
 - If connected to a storage tank where the water level is above the pump impellers, priming is much less difficult but air leaks in the intake will not allow the pump to develop full pressure.
- After the pump is primed and the motor is properly wired, attempt to run the pump briefly before making permanent connections of the discharge piping. It is important to wire the motor properly with red being positive and black being negative. The motor is wired properly when the pump provides the highest amount of pressure and/or capacity.
- After proper pumping is verified, proceed with the final connection of all piping and check for leaks.

NOTE: It is advisable to place the pump as close to the water source as possible. Suction and discharge piping should be kept as large as practical to minimize friction losses. If the suction and/or discharge pipes are long, it is advisable to use 2" suction pipe and foot valve and 1 1/2" or larger discharge pipe depending on the length of the pipeline and the flow rate involved.



SCB Booster Pump System

Wiring Diagrams

Relay Connections w/o LVD

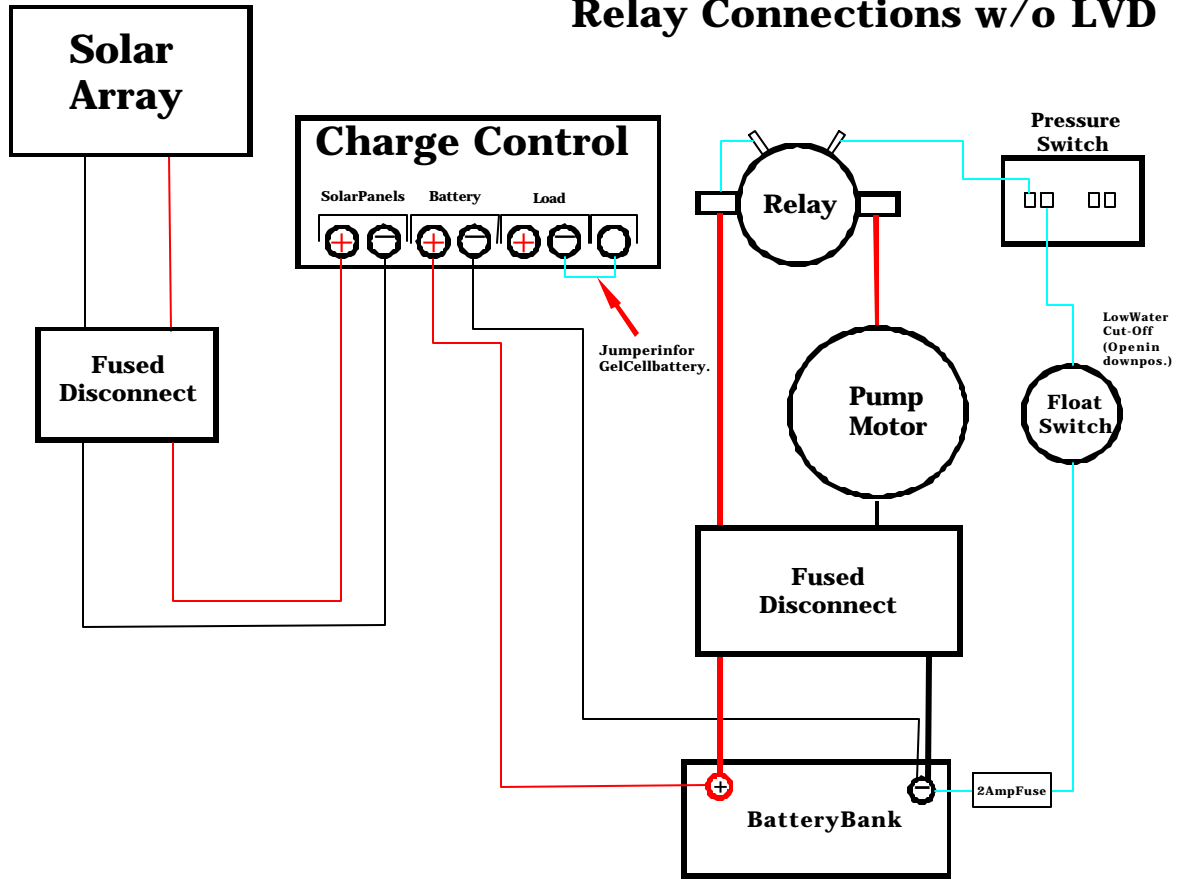

Relay Connections with LVD

