



GUEST 2701A



GUEST 2708A



GUEST 2707A



DSE9461

## 1.5 AMP

The Guest 2701A is an IP67 waterproof, shock resistant, on-board marine battery charger. Energy saving mode automatically shuts off charger when battery is charged. Built in safety includes short circuit, over voltage, over current, and reverse polarity.

## 5 AMP

The Guest 2708A is a fully automatic 5-Stage, IP67 100% fresh and saltwater waterproof and shock resistant, on-board marine battery charger. Built in safety includes reverse polarity, over-current, over-temperature, and ignition protection.

## 8 AMP

The Guest 2707A is fully automatic 5-Stage, IP67 100% fresh and saltwater waterproof and shock resistant, on-board marine battery charger. Built in safety includes reverse polarity, over-current, over-temperature, and ignition protection.

## 10 AMP

The DSE9461 can be programmed for different charging curves to maximize the life of the battery using a 3-stage charging profile with adjustable current limit (Max 10A). This model can be used as a battery charger, power supply or both at the same time. Analog voltmeter and ammeter along with LCD display allow easy monitoring of the charging system. A battery failure contact is linked to the digital genset controller to indicate a loss of power to charger. Required for NFPA 110 applications.

# SPECIFICATIONS

# BATTERY CHARGERS

## 2701A

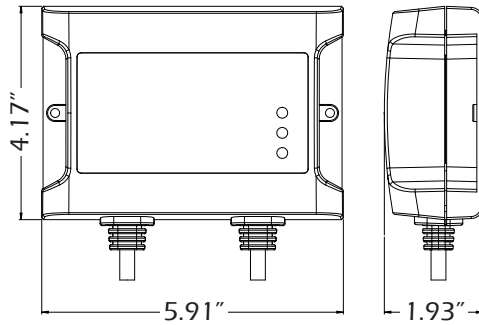

### Average Voltage

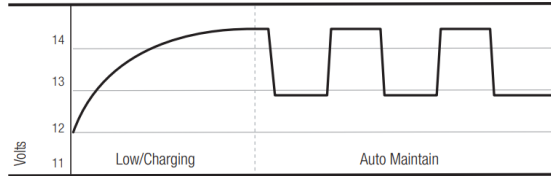

### LED Display

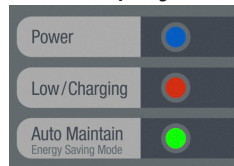

### Guest 2701A

Voltage	12V DC
Max Current	1.5 Amp
AC Input	120 VAC, 60Hz
Operating Temp Range	-10° C thru +50° C
Housing Material	Extruded Aluminum
Connections	Ring Terminals Alligator clips
Battery Type	12V Flooded, Gel & AGM
Protections	Short Circuit Over Voltage Over Current Reverse Polarity
Ingress Protection	IP67 100% Waterproof
Energy Saving	Yes
Monitor Display	LED indicator
Failure Indicator	N/A
Dimensions (L x D x H)	5.9" x 1.9" x 4.2"

## 2708A

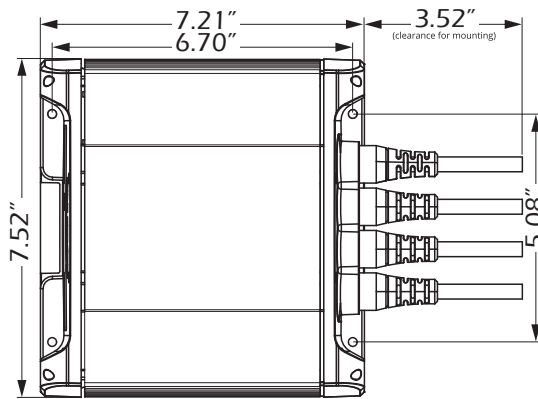

### Fully Automatic 5-Stage Performance

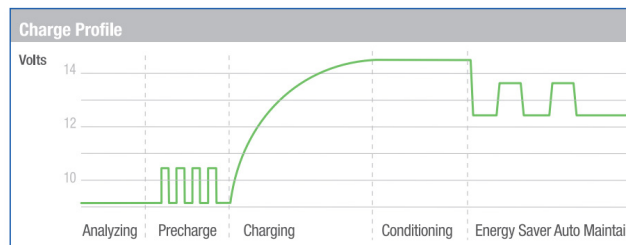

### LED Display

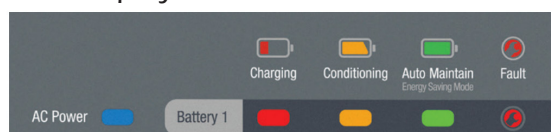

### Guest 2708A

Voltage	12V DC
Amps	5
Input AC Voltage	90-135V 50/60Hz
Operating Temp Range	-10° C thru +50° C
Banks	1
Amps Per Bank	5
AC & DC Cord Length	6 FT
Housing Material	Extruded Aluminum
Connections	NEMA 5-15 AC Plug DC Ring Terminals
Battery Type	12V Flooded & AGM
Protections	Over Voltage Over Current Reverse Polarity Over Temp Ignition Protection
Ingress Protection	IP67 100% Waterproof
Energy Saving	Yes, 5-Stage
Monitor Display	LED indicator
Fault Detection	Yes
Warranty	2 Yrs

# SPECIFICATIONS

# BATTERY CHARGERS

## 2707A

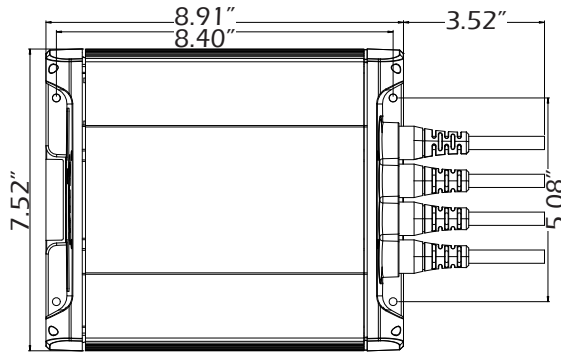

### Fully Automatic 5-Stage Performance

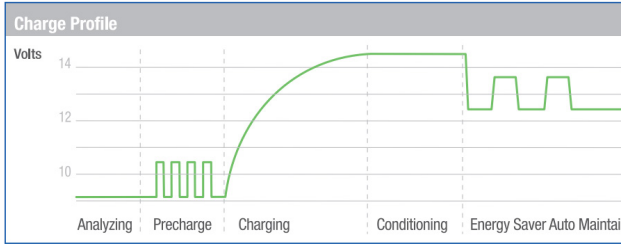

### LED Display

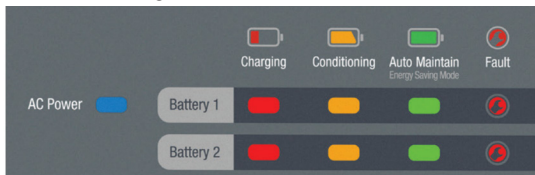

### Guest 2707A

Voltage	12/24V DC
Amps	8 (4/4)
Input AC Voltage	90-135V 50/60Hz
Operating Temp Range	-10° C thru +50° C
Banks	2
Amps Per Bank	4
AC & DC Cord Length	6 FT
Housing Material	Extruded Aluminum
Connections	NEMA 5-15 AC Plug DC Ring Terminals
Battery Type	12V Flooded & AGM
Protections	Over Voltage Over Current Reverse Polarity Over Temp Ignition Protection
Ingress Protection	IP67 100% Waterproof
Energy Saving	Yes, 5-Stage
Monitor Display	LED indicator
Fault Detection	Yes
Dimensions (L x D x H)	8.9" x 2.4" x 7.5"

## DSE9461

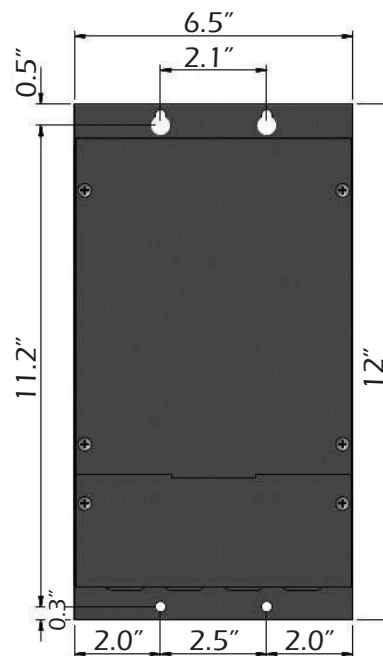

### LCD Display



### DSE9461

Voltage	12/24V DC
Amps	10
Input AC Voltage	90-305V 48-64Hz
Operating Temp Range	-30° C thru +55° C
Temp Sensor Input	PT1000
Charge Failure Relay	3A @ 30V DC
Housing Material	Metal
Battery Type	12/24V
Protections	Over Voltage Over Current Short Circuit Reverse Polarity Over Temp Battery Charger Failure
Energy Saving	Yes, Eco-Power
Compliance	NFPA 110
Monitor Display	LCD Display
Fault Detection	Yes
Dimensions (L x D x H)	6.5" x 4.3" x 12"

Specifications are subject to change without notice.

225 S. Cordova Ave Le Center MN • 1-800-733-2112  
www.wincogen.com