

## ONE Cartridge Tank® Filtration System

The ONE® Cartridge Tank® is a direct replacement for small and inefficient 2½" or 4½" housings, or expensive Stainless Steel cartridge housings, and offers extended service and life, and a more cost-effective and efficient filtration solution.

Lightweight and cost effective with multiple configuration options, from high flow commercial/industrial applications to stand-alone residential Point-of-Entry (POE) installations for city and well water applications, this is the filtration solution of the future...100% non-metallic! The Cartridge Tank® is a high performance, NSF 42 listed device and has been tested to 100 psi operating pressure with 4:1 Burst Safety Factor.

### Features & Benefits

- 100% non-metallic!
- Patented no-tools necessary snap-ring design
- Multiple filtration solutions **OR GR YE BL WH**
- Full 1¼" and 2" plumbing connection options
- Large capacity filter configurations
- Simple and easy change-out of cartridges.
- Match the filtration solution with flow rate requirements
- Extended service life, contaminant removal, and dirt holding capacity
- Low pressure drop = high flow
- Replacement option of pitcher, faucet, bottled water and/or refrigerator filters
- Reduction in frequency of replacing common 2½" or 4½" housings...Bigger is Better

### Applications

- Ideal for Residential, Foodservice, Rental Fleets, Commercial and Industrial Applications
- Make-up Water, RO Pre-filtration, Cooling Towers, Chill Water Loops, Metal Finishing
- Process Water (turbidity, particulate, colloidal suspensions)
- City water applications where water softeners are a hard sell

### Technical Schematics

#### Recommended:

Drain installed on inlet side of system, for removal of contaminants in sediment applications. Drain installed on outlet side of system, for flushing of new cartridges that have dust (i.e. Blue Series)

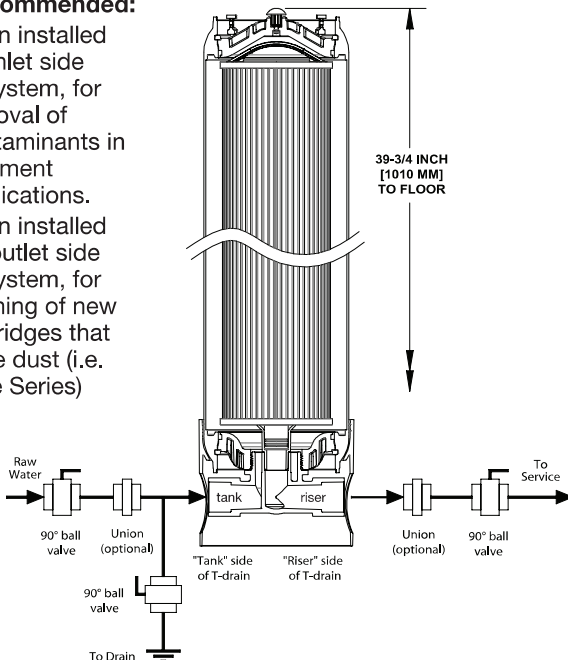

This pressure vessel is tested and certified by NSF International against NSF/ANSI Standard 61 for materials and structural integrity requirements

COMPONENT

**GNE**  
Water Filtration Simplified®



### Models and Components

Units sold fully assembled. Available Plumbing Connections:

Item #: SCT125 - 1 ¼"

### Color-Coded Cartridge Filtration Series

**OR GR YE BL WH**

Item #: SCT-1/4NPTLID



Top Cap option with pressure release Valve & Removal Handles

Item #: SCT-2.5LID



2.5" Threaded top/bottom Res./LC Cap threaded connection.

Item #: SCT-RETAINRING



Snap Ring with I.D. Tag connection.

Item #: SCT-2.5DRAIN  
SCT-2.5ADAPTER



2.5" Bottom Drain Plumbing for Res./LC Filters.