

XP250 INSTALLATION AND OPERATION MANUAL



7317 Jack Newell Blvd North
Fort Worth, Texas 76118-7100
817.595.4969 voice, 817.595.1290 fax
800.886.4683 toll free
website www.exeltech.com



Manufacturer of UL Listed Products



XP250 INSTALLATION AND OPERATION MANUAL

Copyright © 2001 Exeltech Inc. All rights reserved. This Document may not be copied, photocopied, reproduced, translated or converted to any electronic or machine-readable form in whole or in part without prior written approval of Exeltech, Inc.

Acknowledgments

Project Management: Ben Baker and John Goetz

Writing: Gary Chemelewski and David Bond

Copy Editing: Ben Baker

Art, Photography and Layout: John Goetz

May 2002

Exeltech
7317 Jack Newell Blvd North
Fort Worth, Texas 76118-7100

Table of Contents

Introduction 1.0	<i>page 3</i>
Standard Features 2.0	<i>page 5</i>
Installation 3.0	<i>page 7</i>
Operation 4.0	<i>page 10</i>
Appendix A	<i>page 11</i>
Appendix B	<i>page 12</i>



Introduction

1.0

Thank you for purchasing the finest sine-wave inverter in the power conversion industry. Exeltech's journey to excellence includes the first affordable sine-wave inverter, first modular inverter system, first N+1 redundant inverter system, and the cleanest sine-wave output in the industry. Exeltech strives to manufacture products of the highest possible quality and is dedicated to 100% customer satisfaction. Proudly built in the USA with American parts, Exeltech is committed to TL 9000 standards and beyond, adding people and procedures continually to further improve quality and customer service. We welcome you as a customer to the Exeltech family. Congratulations!

Exeltech's XP series inverters provide the cleanest, best regulated sine-wave output over the widest DC input of any inverter on the market today. They are extremely low in total harmonic distortion; specified to 2%, and typically better than 1.5%. Total harmonic distortion is typically 0.8 to 0.9%. Remaining distortion is a result of residual switching noise, which amounts to a very clean 25 KHZ sine-wave superimposed on the fundamental output. No significant harmonics of 25 KHZ exist. This spectral purity will exist over the inverter's entire operating envelope, including non-linear and reactive loads. As long as peak output current remains less than 300% of rated current, total harmonic distortion will remain within the 2% spec. Peak current capability of the inverter is key to understanding its operational envelope. As long as the inverter is supplying less than this amount, it will function properly and operate virtually any load.

Many inverters are rated in Volt-Amps (VA), as opposed to Watts. This is in an attempt to make an inverter or UPS (Uninterruptible Power Supply) appear larger than it really is. The only fair way to

specify these products is in Watts (W), which is power the inverter can actually deliver. If Exeltech inverters were specified in VA, Our 1100 Watt inverter could be rated at 1375 VA at .8 power factor, 1570 VA at .7 pf, or an incredible 2200 VA at .5 pf. It is confusing to specify a product in VA because the power factor must also be specified. Exeltech's XP-Series inverters can output their full rated power continuously up to 30° C (86° F).

The inverter can maintain a spectrally pure output with any load due to a specially designed non-linear control loop in the primary DC-to-DC converter. This circuitry is one of three circuits that protect the inverter from any overload condition.

XP-250

These inverters are capable of exceeding their rated power by 10% for a limited time. The inverter's capability at this level is primarily dependant upon temperature. If output power is exceeded, output voltage is reduced to a level that will provide the inverter's rated power to the load by clipping tops of the waveform. The inverter can operate safely in this mode indefinitely. Should the overload condition clear, the inverter will again provide the cleanest sine-wave in the industry.



Standard Features 2.0

DC INPUTS: A two-pole connector is provided under the rear cover. The rear cover must also be removed to access this connector. Use Appendix "A" to choose the appropriate gauge wire for your specific model. A 2 pole female connector is provided.

"REMOTE" CONNECTION: is on the six-pole, plug-in connector, located under the rear cover.

AC OUTPUTS: has one NEMA-15 outlet (standard wall receptacle), located on the front panel. Additionally; may be hard-wired to appliance / load using connections furnished on the six-pole, plug-in connector, located under rear cover.

230 VAC: inverters have an **IEC-320** receptacle located on the front panel.

COOLING: convection cooled.

DC POWER ON LED: located on the front panel, will be "ON" when inverter is powered up and DC power is available.

LOW BATT / THERM BUZZER: produces an audible alarm if DC input voltage falls to a level within 2% to 4% of the low limit of inverter, or, if there is an over temperature condition.

ON/OFF SWITCH: located on front panel; turns the inverter on and off.

OVER VOLTAGE PROTECTION: If input voltage to the inverter exceeds set limits, the inverter will immediately shut off without warning. When input voltage returns to normal range, the inverter will

immediately restart. Since high over voltages tend to have very fast edges, the inverter must shut down quickly to protect itself. This kind of fault usually occurs if the battery is suddenly disconnected from the system and the battery charger continues to supply current. When battery voltage falls to within 2% to 4% of low line voltage, the LOW BATT / THERM buzzer will sound. If the condition continues without reducing load to the inverter or adding charge to the battery, the inverter will shut off. When voltage rises to approximately 95% of nominal battery voltage, the inverter will turn back on and the alarm condition will clear. The inverter can be manually reset by cycling the on/off switch. This will reset the protection circuitry and turn the inverter on at any voltage above minimum voltage.

OVER TEMPERATURE PROTECTION: The inverter is also protected against overheating. It will provide its full rated output up to the temperature listed in the specification sheet. If it is subjected to higher ambient temperatures, or air circulation is blocked, the inverter may overheat. If the LOWBATT/ THERM buzzer sounds, immediate action is required or the inverter will shut down. Either reduce load, or provide more cooling in the immediate environment. If no action is taken, the inverter will likely shut down within 2 minutes. When the inverter shuts down, the alarm condition will persist. Since the inverter has eliminated its load, it will cool fairly quickly. It will automatically restart when it has cooled sufficiently, and the LOW BATT/THERM alarm will clear. If the internal temperature is over 105C a warning buzz 5 C before shut off.

If rated output power is exceeded, output voltage is reduced to a level that will provide the inverter's rated power to the load by clipping tops of the waveform. The inverter can operate safely in this mode indefinitely. The overpower protection circuit will recover instantly when the overpower condition clears.



Installation

3.0

CAUTION: It is essential to read and understand all Warnings, Cautions, and Notes before any connections are made to the Unit or System. If further assistance is needed call (817)595-4969 and ask for Customer Service.

WARNING: The inverter is designed to operate from a battery. Performance cannot be guaranteed, and damage can result when a charger or power supply is used without a battery in the circuit.

WARNING: The AC neutral lead is internally bonded to chassis; chassis must be bonded to earth ground through the external ground connector located on the unit. The negative or positive terminal of the battery (DC source) must be bonded to earth ground; it is recommended that it be to the same earth ground used for AC ground. Refer to the figure below for wiring illustration.

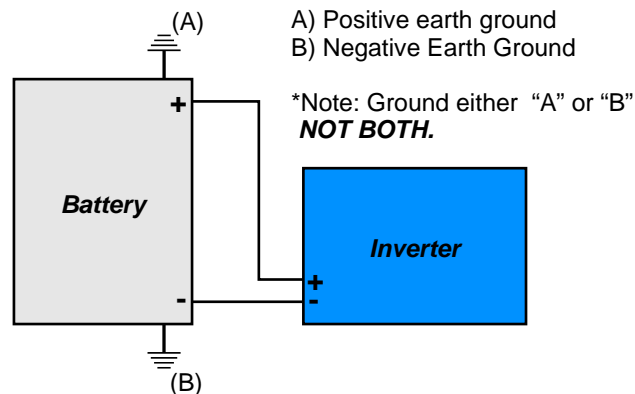

CAUTION: Before any connections are made to the unit or system, be sure to disconnect the battery terminals. Always disconnect the grounded battery terminal first. When re-connecting, connect ungrounded terminal first, and grounded terminal last.

CAUTION: Polarity of leads is critical to avoid damage to the unit or system. Check batteries and battery cables for correct polarity and voltage.

CAUTION: Observe all National and Local Electric Codes when connecting AC Power Connections.

INSTALLATION (Location)

Mounting location is critical to performance and life span of the inverter. Heat and moisture are the two worst enemies of any electronic device. Therefore, when choosing a mounting location, consider the following requirements listed in order of importance:

1. Inverter must be sheltered from the elements. Select a clean, dry location.

2. Inverter requires adequate ventilation for cooling. With proper cooling, the inverter will operate efficiently and meet its published ratings. All models can be mounted in several positions. Best position, vertical. Second best, vertical with inverter front facing up. Third, horizontal.

The **XP-250** will perform best when mounted vertically. This will allow warm air to rise through vent holes on top, drawing cool air through vent holes on the bottom.

3. Inverter should be mounted as close to the battery as possible. Shorter wire has less resistance, which translates to increased efficiencies.

INSTALLATION (Wiring)

An in line fuse is recommended to protect the battery and wiring to the inverter. This fuse should be located very close to the battery positive (+) terminal. To select appropriate size fuse, consult the "Rated and Peak Current" table in Appendix "A".

XP-250: a two-pole connector is provided under the rear cover. The rear cover must also be removed to access this connector (see Appendix "B"). Use Appendix "A" to choose the appropriate gauge wire for your specific model. A 2 pole female connector is provided.

1. Disconnect the **grounded (-)** terminal of battery and make sure

the charger and inverter are off.

2. Make DC input connections to the inverter as illustrated in Appendix "B". Attach DC wires to the 2 pole female connector.

3. (Optional) Using 12-18 AWG wire, make Remote On/Off connection from the rear panel terminal labeled "REMOTE" to one pole of a small toggle switch. Then from the other pole of toggle switch, make a connection to battery negative (-).

4. Make sure the toggle switch is off.

Note: in order for the Remote On/Off switch to operate inverter, On/Off switch on the front panel must be off.

5. If the appliance / load will be hard-wired to the inverter instead of or in addition to the outlets provided on the front panel, see Appendix "B".



Operation

4.0

TURN ON INVERTER:

XP-250: Turn inverter on using toggle switch on front panel, or the "REMOTE" switch if installed. LED next to the switch will illuminate, indicating the inverter is operational.

Note: If using "REMOTE" switch, the front panel switch must be off. (If either switch is "on", the inverter will turn on. Both switches must be off for the inverter to turn off.)

TURN ON APPLIANCE/LOAD:

1. Check Input Power Requirements of the appliance. Make sure that it is less than Rated Output Power of the inverter. If more than one appliance will be run simultaneously, the sum of their Input Power Requirements must be less than Rated Output Power of the inverter.
2. If appliance/load has been hard-wired to the barrier terminal strip as illustrated in Appendix "B", then turn appliance on. Otherwise;
3. Plug the appliance into the receptacle provided on front panel, then turn appliance on.

Note: It is recommend that the inverter be turned ON before the appliance/load.

APPENDIX A

Input Power Requirements:

MODEL	NORMAL VDC (TYPICAL)	MINIMUM VDC CUT-OFF / ALARM (TYPICAL)	MAXIMUM VDC (TYPICAL)	RATED CURRENT	PEAK CURRENT
XP-250 / 12VDC	13.8 VDC	10.4 / 10.6 VDC	16.5 VDC	24.5 A	27.8 A
XP-250 / 24VDC	27.6 VDC	19 / 21 VDC	33 VDC	12.3 A	14 A
XP-250 / 48VDC	55.2 VDC	41.5 / 42.5 VDC	62 VDC	6.1 A	6.9 A
XP-250 / 66VDC	75.9 VDC	57.5 / 58.5 VDC	91 VDC	4.5 A	5 A
XP-250 / 108VDC	124.0 VDC	94 / 95 VDC	149 VDC	2.7 A	3 A

Recommended Input Wire Sizes (For Variable Distances from the Battery):

MODEL	LESS THAN 5'	LESS THAN 10'	LESS THAN 15'	LESS THAN 20'
XP-250 / 12VDC	8 AWG	4 AWG	4 AWG	2 AWG
XP-250 / 24VDC	12 AWG	10 AWG	8 AWG	6 AWG
XP-250 / 48VDC	18 AWG	16 AWG	14 AWG	14 AWG
XP-250 / 66VDC	18 AWG	18 AWG	16 AWG	16 AWG
XP-250 / 108VDC	18 AWG	18 AWG	18 AWG	18 AWG

Note: The table specifies standard wire sizes (not smaller than 18 AWG) that will provide less than a 2% voltage drop at Low-line Input voltage and Rated Output Power.

XP-250 Mechanical Specifications:

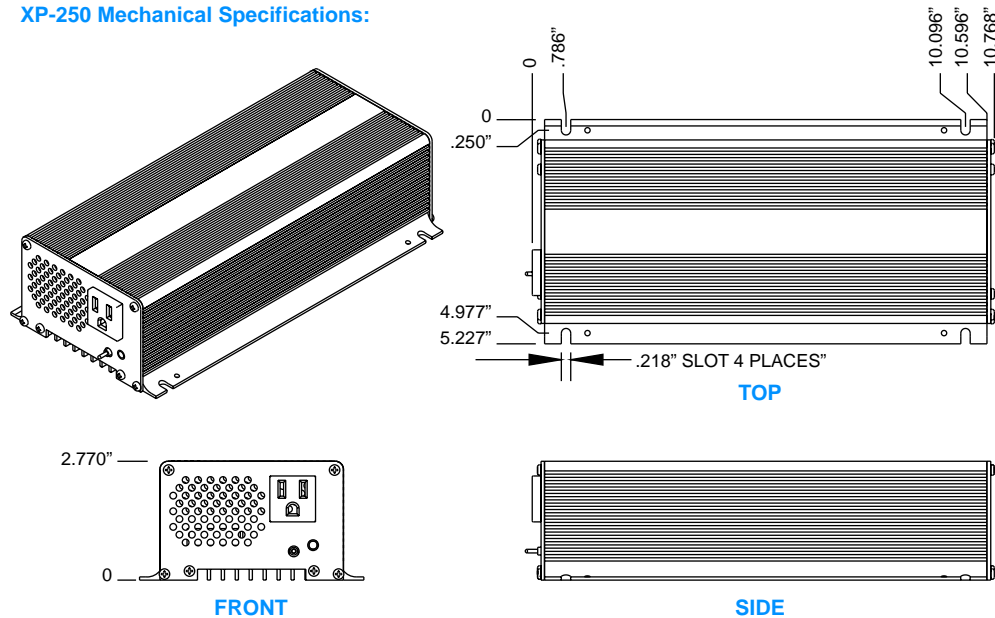

APPENDIX B

Note: Use Rated Current and voltage in Appendix "A" to select an appropriate Toggle Switch or Relay for your specific model inverter.

XP-250 with DC Toggle Switch:

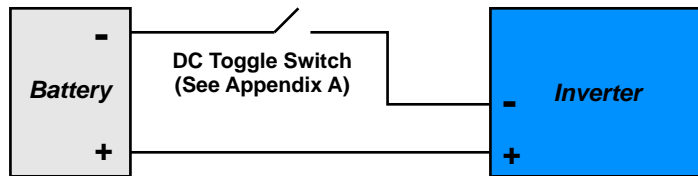

XP-250 with DC Relay:

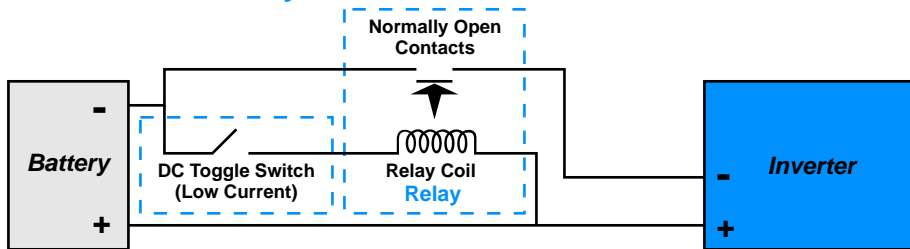

INSTALLATION

CAUTION: Be sure to disconnect all DC power to installation wiring. Be sure to disconnect batteries and chargers. Make all connections to the inverter **BEFORE** connecting DC power to the battery.

XP-250 Rear View (AC/DC Connections):

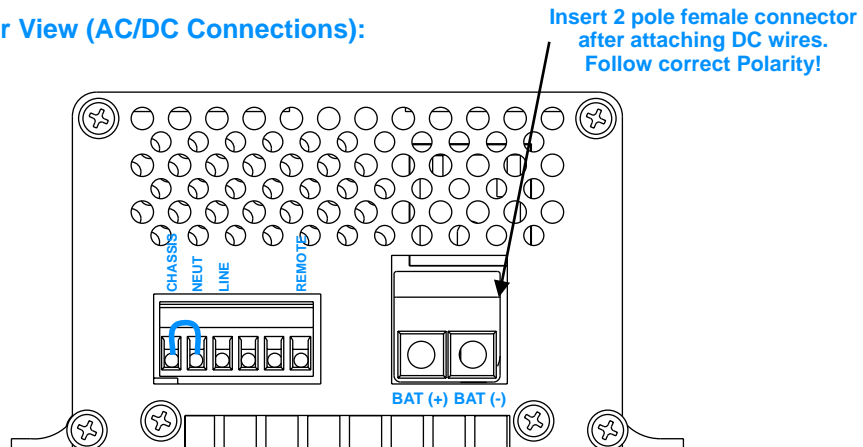

XP250 INSTALLATION AND OPERATION MANUAL

Made in the USA

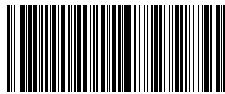

9 3 1 - X 2 1 M * - * 0 G

Document subject to change without notice.
931-X21M*-*0G
MAY 24, 2006.



7317 Jack Newell Blvd North
Fort Worth, Texas 76118-7100
817.595.4969 voice, 817.595.1290 fax
800.886.4683 toll free
website www.exeltech.com